



EPROPULSION ELECTRIC BOATING

2024 12 Years of Innovative Electric Marine
Propulsion Systems and Services



Why Electric



Better Experience

Quiet

Our electric boat motors are all-but silent... so you don't have to shout at your fellow crew, and won't scare away the wildlife or fish.

Clean

There's no fuel or oil to leak out, so no risk of spillage or stains on your boat, car or clothing.

Emissions-Free

No exhaust fumes to poison you and your crew, or make you feel seasick.



Easier Operation

Reliable

With fewer moving parts, electric motors are inherently less likely to go wrong.

Digitized

Electronic control systems give you push-button start, fingertip control, and at-a-glance operational data.

Low Maintenance

Electric motors require much less maintenance than combustion engines - and all-but zero maintenance for direct-drive models.



Kinder to the Earth

Renewable Energy Sources

Batteries can be recharged by hydrogenation (built into many ePropulsion systems), wind turbines or solar panels.

Cost Effective

Low maintenance, and far lower (or even zero) energy costs generate significant savings, especially for commercial users.

Environmentally Friendly

Zero emissions boating helps the environment, makes you feel good, and gives you access to waters where combustion motors are banned.



Why ePropulsion

Product Innovation

We're always listening to our customers, and welcome your input. This knowledge and feedback helps drive our process of continuous product development and innovation, always striving to improve the user experience. Electric outboards are much nicer to use than their combustion predecessors, and it's our aim to make ePropulsion electric outboards the nicest of them all!

Competitive Pricing

There are many factors that will influence your decision to make the transition from a combustion engine, and price is always going to be one of them. Our aim is to supply top rank products at highly competitive prices, without compromising on quality.

Quality Excellence

We know the marine environment is harsh, so we simulate the most extreme conditions – such as heat, cold and salinity – in our QA laboratory, before design finalisation. And once an item is in production we collect and analyse quality-related data, to assess and predict any components that may be problematic. This feeds into our process of continual development.

Customer Service

As the leading company in our sector, we have a strong and established dealer network operating in over 60 different countries. If you need us, we are always there – with fast and responsive customer support – making ownership of an ePropulsion product easy and hassle-free.





Customer Satisfaction Matters the Most



“

Our focus every single day is to continually improve all aspects of our customer experience.

”

— Danny Tao
ePropulsion CEO & Co-Founder



Customised Solutions

Spirit 1.0 RS21 Drive

“ You can usually expect some teething issues with new boat designs but the ePropulsion solution has been seamless. Their system works perfectly and is one of the easiest systems we fit on the boat, even when we are retrofitting on boats away from the factory. It's silent, robust and really complements the overall quality of the RS21 package.”

— Alex Southon, RS Sailing CEO



ePropulsion has manufactured and supplied a bespoke electric propulsion system for the RS21 keelboat since 2019, with several hundred now sold. Based on the popular Spirit outboard, it's a flush-fitting retractable design that minimises drag when sailing whilst providing clean, quiet power for harbour manoeuvres and getting to/from the start line.

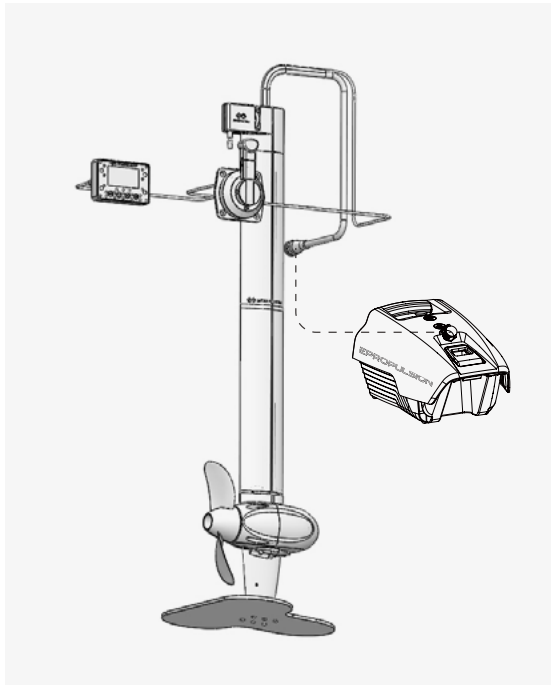



Innovative Partnership

With a shared mission for greater sustainability, ePropulsion is working in partnership with SailGP to provide the Spirit 1.0 Evo and Navy 3.0 Evo electric outboard motors for the league's event support tenders and power SailGP's community, education and outreach initiatives since Season 2.

Sail GP's cutting edge autonomous race marks are powered by ePropulsion Navy 6.0 Evo. These race marks are fully electrically powered and operated via GPS, which means there is no need to anchor each mark to the sea bed, avoiding damage to the local environment.

This partnership resulted in a remarkable reduction of 3 tonnes of CO2e emissions in Season 3, underscoring our shared commitment to sustainability. ePropulsion and SailGP will continue to work together to help revolutionize the sports and entertainment industry focusing on an acceleration towards clean energy.

SailGP is an adrenaline-fuelled global sailing competition and the first climate-positive sports and entertainment property with the goal of accelerating the transition to clean energy.

SAIL GP

OFFICIAL ELECTRIC OUTBOARD
SUPPLIER FOR SMALL CRAFT

“ We are excited to work with like-minded partners that share our vision of accelerating the transition to clean energy. Our partnership with ePropulsion is the first of many steps to meet our ambitious target of being fully powered by nature on-water by 2025 and is a great example of how, through technology and innovation, we can help create a better planet. ”

- Fiona Morgan, SailGP Global Director of Purpose and Impact



ePropulsion has forged a strategic partnership with RYA as the Official Innovation Partner for the years 2023-2027. Charting a new path for sustainable nautical recreation over the next four years, this collaboration aims to contribute to deploy avant-garde electric propulsion systems that are not just efficient, but also environmentally considerate.

The RYA exists to get more people into boating and watersport activities, promote safe boating practices and raise the standards of yachting and sailing in the UK through its network spanning over 58 countries.



“ This is a key partnership for the RYA as we look to a future of quiet, zero carbon boating. We’re seeing a huge interest from members and affiliates in switching to electric drive, and rapid advances in technology driven by companies such as ePropulsion mean this is now readily achievable for most recreational boaters. ”

-Phil Horton, Manager for Environment and Sustainability, RYA.



Product Range

Outboards

eLite
500 W



Spirit 1.0 Plus
1 kW



Spirit 1.0 Evo
1 kW



Spirit 1.0 Evo Remote
1 kW



Navy 3.0 Evo
3 kW



Navy 6.0 Evo
6 kW



X12
12 kW



Outboards

X20
20 kW



X40
40 kW



Pod Drives

Pod Drive 1.0 Evo
1 kW



Pod Drive 3.0 Evo
3 kW



Pod Drive 6.0 Evo
6 kW



Pod Drive 12 eSSA
12 kW



Inboards

H-Series
60-250 kW



Inboards

I-10
10 kW



I-20
20 kW



I-40
40 kW



Batteries

Spirit Battery Plus*
1276 Wh / 48 V



E60 Battery
3072 Wh / 48 V



E163 Battery
8345 Wh / 48 V



G102-100 Battery
10240 Wh / 96 V



Controls

Evo Tiller



Evo Remote
Control



Evo Side Mount
Control



Evo Dual Remote
Control



Smart Throttle
Smart Display 5"



Smart Display 10"
Digital Helm



* Also applicable to Spirit 1.0 Evo & Spirit 1.0 Evo Remote

Versatile Applications

For Sailboats

ePropulsion electric outboards enable one-design sailboats to leave and return to the marina quickly, silently and with great manoeuvrability. Owners of daysailers and small cruising sailboats love pod drives because they are space-saving, quiet and vibration-free. The hydrogeneration and solar charging also allow sailors to travel further and sail more sustainably..

For Work Boats

The electric outboard motor has a simple structure and fewer components than gas engines. It offers a more reliable solution while requiring minimum maintenance. Work boats, commercial boats and rental boats can go further for longer. The quiet and exhaust-free experience also makes life more pleasant for passengers.

For Fishing Boats

Quietness is important when you're fishing... an electric outboard won't scare away your catch! Electric motors are also well-suited to running at trolling speeds for long periods, using minimal electricity and with no risk of "sooting up".

For Dinghies & Tenders

Owners of small boats - inflatables, tenders and sailing dinghies - love our electric outboards. The high capacity batteries and digital display make "range anxiety" a thing of the past, whilst the minimal maintenance requirements save both time and money.





eLite **New** Electric Outboard Motor

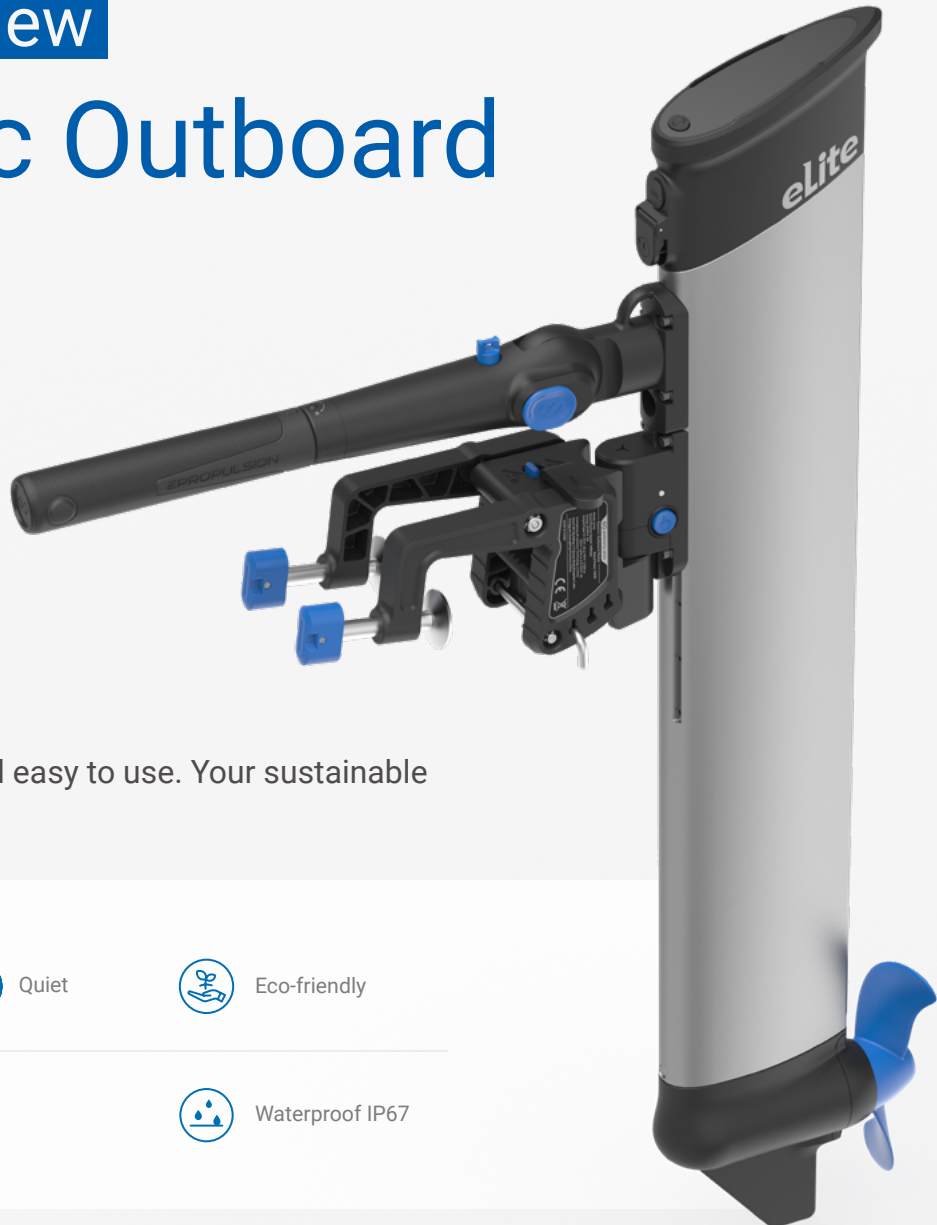

500 W

Efficient, compact, and easy to use. Your sustainable power on the go



Clean



Quiet



Eco-friendly



Minimal Maintenance



Waterproof IP67

Specs*

Nominal Power	500 W
Maximum Power (in Sport Mode)	750 W
Battery	Integrated 378 Wh 25.2 V Lithium-ion
Charger	100 to 240 V AC charger included, 12 V charger optional
Cooling System	Natural cooling
Rated rpm	1500 to 1700
Operating Temperature	-5 to 55 °C
Storage Temperature	-20 to 45 °C
Trim and Tilt	8° / 17° / 26°
Tilt Angle	75°
Shallow Water Mode Tilt Angle	36°
Steering Range	±70°
Dimensions (L x W x H)	297 x 75 x 890 mm (11.7 x 3 x 35")
Motor Weight (excluding bracket)	6.7 kg (14.7 lbs)
Motor Weight (including bracket)	7.9 kg (17.4 lbs)
Adjustable Shaft Length	401 / 362.5 / 322 / 282.5 mm (15.8 / 14.27 / 12.7 / 11.1")

* The specifications are for reference only.

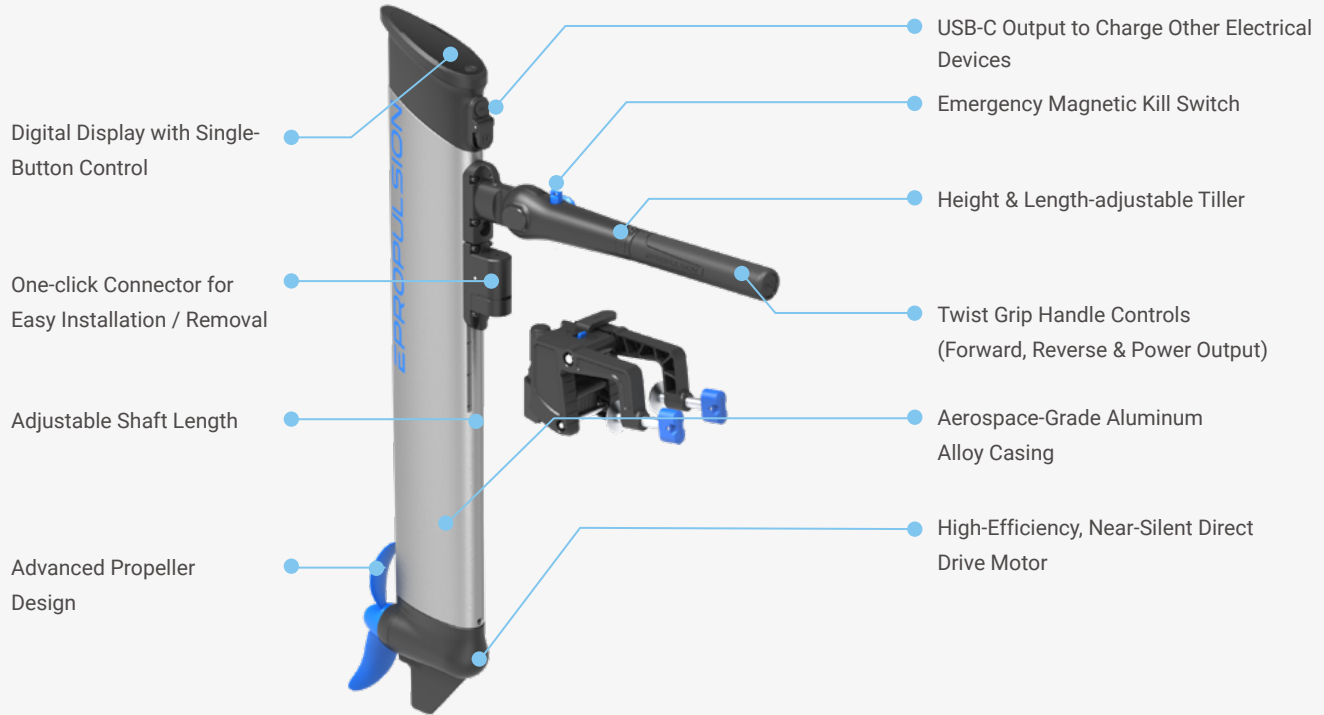

- **Compact size:**
297 x 75 x 890 mm (11.7 x 3 x 35")
- **Lightweight:**
Motor weight (excluding bracket)
6.7 kg / 14.7 lbs
- **One-click removal/installation:**
Motor can be lifted on/off (for charging etc) at the touch of a button, and clamp left on transom. No connections to make, no tools needed.
- **Easy to carry and lift. Weight balances on folded tiller.**
- **Carrying Bag included for easy storage and transport**



Clamp Bracket Functionality

- Quick Release for motor on/off
- 3 leg down trim angles for different transoms
- Partial tilt/shallow water drive at 36°
- Full tilt at 75° for beach landings & storage
- Anti-grounding mode: if the motor hits a rock or other underwater obstacle, it will tilt up automatically to reduce the likelihood of damage

Advanced Tiller

- Extendable
- Fixed or adjustable angle
- Foldable for easy transport
- Ergonomic, easy-grip handle



Intuitive Control and Display

- **Digital Display**
Shows battery level, power output, system status and alerts
- **Single-Button Control**
Select mode, and switch main display between power output and battery level



Integrated Lithium-ion Battery

- Safe and Reliable
- Integrated Smart Battery Management System for more energy-efficient operation and longer battery life
- USB-C output to charge/power other electrical devices
- Supports multiple charging options (220 V AC as standard, 12 V DC and Solar with optional ePropulsion accessories)

Performance & Range*

	Half Power 250 W	Full Power 500 W	Sport Mode 750 W
Speed (km/h / mph)	6.0 / 3.7	7.5 / 4.7	8.3 / 5.2
Running Time (hh:mm)	01:30	00:45	**
Range (km / mi)	9 / 5.6	5.6 / 3.5	/

* The data above is for a single person driving an 8ft aluminium dinghy (total weight 117 kg), in calm conditions. Range and run time may vary with different boat or load, wind and waves, etc

** Sport Mode can last up to 1 minute subject to battery SOC and temperature.



Spirit Series

1 kW / 1276 Wh



Spirit 1.0 Plus
Entry-level Model

Spirit 1.0 Evo
Made for Sailing

Spirit 1.0 Evo Remote
Made for Remote Steering



The Spirit 1.0 Plus & Evo motors are our best-sellers. They're designed for portability, with an integrated, but easily-removable, 1276 Wh lithium battery.

Specs



	Spirit 1.0 Plus	Spirit 1.0 Evo	Spirit 1.0 Evo Remote
Power	1000 W		
Battery Capacity	1276 Wh		
Motor Weight*	10.6 kg / 23.4 lbs	11.3 kg / 24.9 lbs	10.9 kg / 24 lbs
Battery Weight	8.7 kg / 19.2 lbs		
Charging Time	3.5 hrs (Fast charger) / 8.5 hrs (Standard charger)		
Battery Life*	500 cycles at 80% DOD		
Shaft Length	XS: 52.5 cm / 20.7 in S: 62.5 cm / 24.6 in L: 75 cm / 29.5 in	S: 62.5 cm / 24.6 in L: 75 cm / 29.5 in	
Input Voltage	39 to 60 V		
Propeller rpm	1200 rpm		
Propeller	11" × 5.8" 2-blade composite propeller		
Trim / Tilt Angle	0°, 7°, 14°, 21° / 70°	0°, 7°, 14°, 21° / 85°	0°, 7°, 14°, 21° / 85°
Hydrogeneration	✗	✓	✓
Safety Wristband	✗	✓	✓
Display Backlight	✗	✓	✓

* Weight quoted is for the short shaft version. The weight of Spirit 1.0 Evo Remote excludes the control.

*Battery life is based on laboratory testing. Actual battery life may vary depending on operational environment and usage conditions.



Long Range

Thanks to the 1276 Wh large battery, Spirit 1.0 Plus / Evo has longer range than other gasoline outboards and electric outboards. Run times at full power:

Spirit 1.0 Plus / Evo

75 min

Average 1 kW electric outboard

50 min

A FourStroke 3.5HP*

48 min

* The runtime of the above FourStroke 3.5HP is measured with the 0.3 gal (1.1 L) internal fuel tank.

Hydrogeneration

ePropulsion supplies the first and only electric outboard motors that have hydrogeneration functionality on the market. Sailors will love this new feature as it makes sailing more sustainable.

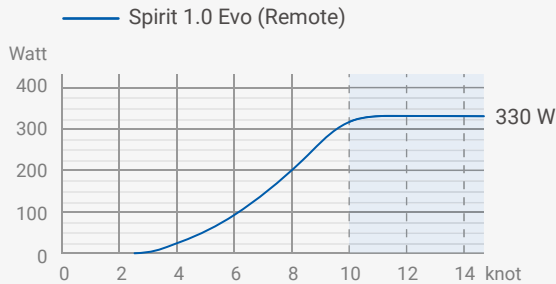

* Spirit 1.0 Evo outboard can drive the propeller to charge the battery (only ePropulsion batteries) through water flow when certain conditions are met (please refer to the user manual in the download center for the required conditions).

* The hydrogeneration data is based on real tests with the anti-ventilation plate installed.

Design

1 1 1 Magnetic kill switch

In case of emergency, pull out the switch to immediately stop the motor.

2 2 Folding/Removable Tiller

The Plus tiller is permanently attached, but folds in line with the leg for easier transport/storage.

The Evo tiller can be left attached and folded, or removed altogether if more convenient.



Spirit 1.0 Plus

3 3 3 Gauge display

Access to battery level, remaining runtime, input power, and voltage, etc.

6 6 Safety wristband

In case of man overboard, it immediately shuts down the motor.

9 9 9 Battery pull latch

Making battery installation easy and quick.

4 4 4 Charging port

It works with both AC charger (included) and 12 V or solar chargers (optional).

7 Evo side mount control

This smooth single lever control works together with a separate 4.3-inch gauge display.

10 Steering tube

Works with a mechanical or hydraulic steering helm and the steering link arm.

5 5 5 Durable metal connector

Made of stainless steel and processed by PVD technology.

8 Evo remote control

Compact, economical and integrated with a 3.4-inch display. Can be wired or wireless.

11 11 11 Anti-corrosion coating

Anodized coating and powder coating which protects the base material from corrosion.





Taking you Further

Performance & Range

Power (Watt)	Speed (km/h / mph)	Running Time (hh:mm)	Range (km / mi)
35	3.5 / 2.2	36:25	129 / 80
65	4.3 / 2.7	19:35	85.3 / 53
125	5.6 / 3.5	10:00	56 / 35
250	7.1 / 4.4	5:00	35.5 / 22
500	8.5 / 5.3	2:30	21.3 / 13.3
750	9.2 / 5.7	1:40	15.3 / 9.5
1000	10 / 6.2	1:15	12.5 / 7.8

*The performance data is based on a 12-foot aluminum boat with one person and one Spirit Battery Plus in calm lake water. The actual speed, range and running time may vary because of different boats, load, weather, etc.

One Charge to Go 35 km

Seattle

Pike Place Market to Golden Gardens Park
Round Trip / 28.0 km or 18 miles

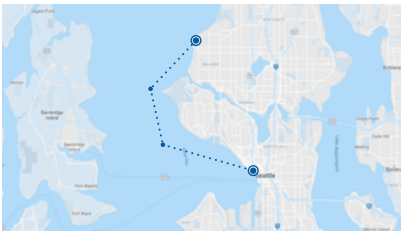

Miami

Miami Seaquarium to North Beach
Round Trip / 28.3 km or 17.6 miles

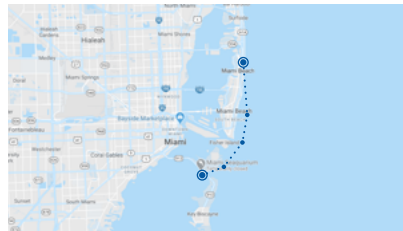

San Francisco

Golden Gate Bridge to Alcatraz Island to Pier 39
Two Laps / 25.7 km or 16 miles

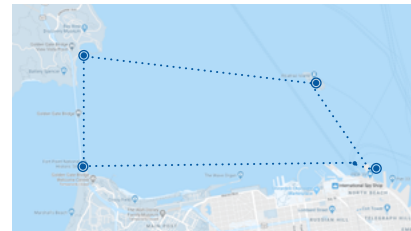



Sailing Enthusiasts Love Spirit Series



We jumped at the chance to test out an ePropulsion Spirit 1.0 Evo electric outboard. Being able to use our dinghy without any petrol and charge the engine from our solar panels indefinitely was pretty intriguing. No smelly jerry cans on deck, no noisy engine that breaks down every so often, that sounded good.

- Sailing Learning By Doing

Follow Sailing Learning By Doing:

-  Sailing Learning By Doing
-  Sailing Learning By Doing
-  @vernondeck





Watch the review video here

“We’ve had our ePropulsion Spirit 1.0 for three years now, and we absolutely love it. It has been 100% maintenance-free the entire time. We haven’t had to do anything. With our old outboard, we always had this feeling of dread. But with the ePropulsion, there’s never a feeling of uncertainty; it’s a feeling of reliability. Because every time I press the power button and twist the throttle it just goes. Like there’s nothing else to it... if only everything on the boat worked that way. Not having to worry about getting fuel, not having to store fuel, not having to fix anything on it. It’s such an easy thing to deal with. It warms my heart.

- Sailing Soulianis

Follow Sailing Soulianis:

-  Sailing Soulianis
-  Sailing Soulianis
-  @sailingsoulianis



Watch the review video here





Spirit Battery



Floating Battery

The battery is removable, for better portability and easier installation... But there's always a slight risk you could drop it in the water! That's why we developed the Spirit battery to float!



Solar Charging

The Spirit battery can be charged at a rate of up to 180 W, including from solar panels (optional solar panel/charger required). This is possible while the motor is running, so on a sunny day and at low speeds you could even run off solar power all day. The Spirit solar panel is lightweight and foldable too.



Spirit Battery Power Output Set

With the Spirit battery power output set (optional), it's possible to power other electronics on board, such as a fridge or fish finder. A display shows battery level and any errors. Note: output is 48 V, so you may also need a DC-DC converter.



Effortless Battery Replacement

If you need even more range, the easiest way is to buy another Spirit battery... and it's much safer/cleaner to store than a can of petrol/gas! Changing over the batteries is very simple, and should take less than 30 seconds (disconnect cable, lift latch). There is also an accessory for attachment of external 48 V batteries, if preferred.

Evo Controls

ePropulsion offers excellent compatibility between different control systems. They have all been developed on the same system platform, and work seamlessly with Evo motors and other Evo components.



Evo Tiller

Ergonomic and removable design
3.4-inch integrated display with
backlight



Evo Remote Control

Wireless or wired connection
3.4-inch integrated display with
backlight



Evo Side Mount Control

4.3-inch separate display with backlight
Accidental trigger protection when in
neutral



Evo Dual Remote Control

Sync Mode
Docking Mode
4.3-inch separate display with backlight



Safety Wristband

Easy-to-use and additional safety.

- Man overboard protection
- Wireless connection
- Waterproof IP67
- Max connection up to 8 wristbands per motor

With the aim of making boating safer for all, ePropulsion now offers wireless safety wristbands for the Evo series motors. In case of a man overboard situation, the safety wristband immediately shuts down the motor. Each Evo motor can connect with up to 8 safety wristbands. This function also keeps you safer when you're alone and not in close proximity to the kill switch. You, your families, friends, and even your dogs can all be protected.

* Safety wristband is compatible with Evo tiller and Evo remote control, not compatible with Evo side mount control or Evo dual control.



Information Display

Keeping you informed.

- Battery level
- Remaining runtime
- Remaining distance*
- Realtime power
- Error codes
- Speed*
- Realtime voltage
- Hydrogeneration power / status
- Metric and imperial conversion
- Safety wristband connection status

* Not available on Spirit Series or Pod Drive 1.0 Evo.

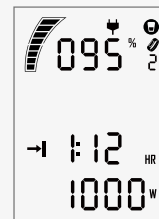



Navy 3.0 Evo / 3 kW

Navy 6.0 Evo / 6 kW



Navy 6.0 Evo
6 kW

Navy 3.0 Evo
3 kW

Navy series electric outboard motors deliver simple and efficient power equivalent to about 3 kW or 6 kW combustion motors, depending on model. Sleek, easy to use and eco-friendly, these outboards will be a staple of your boating experience for years to come.

Features

Brushless Direct Drive Motor

The Navy series motors are direct drive, unlike most competitors at this size. Eliminating the gearbox means fewer moving parts, less noise and vibration, and better reliability.

Hydrogeneration

The ePropulsion Navy series is the only range of outboards at this size with hydrogeneration functionality. When the boat is sailing, the propeller turns the motor, which recharges your batteries... no generator or shore power required!

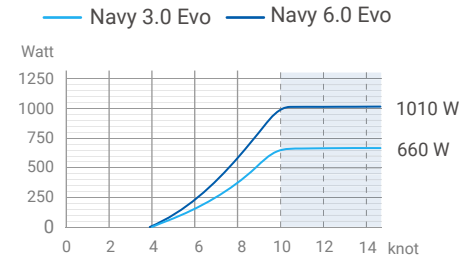

* Navy 3.0 Evo and Navy 6.0 Evo outboards can drive the propeller to charge the battery (only the ePropulsion battery) through water flow when certain conditions are met (please refer to the user manual in the download center for the required conditions).

Specs



	Navy 3.0 Evo	Navy 6.0 Evo
Power	3 kW	6 kW
Operation Voltage	48 V (Input Range 39 to 60 V)	
Outboard Weight*	24.3 kg / 53.6 lbs	36 kg / 79.4 lbs
Shaft Length	S: 63.4 cm / 25 in L: 75.9 cm / 29.9 in	
Static Thrust	590 N / 132.6 lbs	1243 N / 279.4 lbs (13.4" × 8.5" composite propeller)
Propeller rpm	2300 rpm	1500 rpm
Propeller	10.2" × 6.7" 2-blade composite propeller	12.6" × 10.8" 3-blade composite propeller 13.4" × 8.5" 3-blade composite propeller 12.6" × 8.7" 3-blade aluminium propeller (optional)
Trim / Tilt Angle	0°, 5°, 10°, 15° / 60°	
Hydrogeneration*	✓	✓

* The outboard motor weight quoted is for the short shaft version, excluding the control weight.

* The hydrogeneration data is based on real tests with the anticavitation plate installed. Navy 6.0 Evo is tested with a 13.4" × 8.5" three-blade composite propeller.



Taking you Further

Performance & Range

Navy 3.0 Evo (Watt)	Speed (km/h / mph)	Runtime (hh:mm)	Range (km / mi)	Navy 6.0 Evo (Watt)	Speed (km/h / mph)	Runtime (hh:mm)	Range (km / mi)
300	6 / 3.7	13:20	79.3 / 49.3	500	6.5 / 4	18:00	116 / 72
550	7.5 / 4.7	7:25	56.3 / 35	1000	8 / 5	9:00	72 / 45
1000	8.6 / 5.3	4:00	34.1 / 21.2	2000	10.8 / 6.7	4:30	48.6 / 30.2
1500	9.7 / 6	2:40	25.7 / 16	3000	13 / 8	3:00	39 / 24
2000	10.2 / 6.3	2:00	20.4 / 12.6	4000	18.5 / 11.5	2:15	41.7 / 25.9
2500	12.8 / 8	1:35	20.5 / 12.7	5000	21.8 / 13.5	1:50	39.8 / 24.7
3000	16.4 / 10.2	1:20	21.9 / 13.6	6000	24.3 / 15	1:30	36.5 / 22.5

*The performance data is based on a 12-foot aluminum boat with one person, powered by one Navy 3.0 Evo and E80 battery / Navy 6.0 Evo and E175 battery in calm lake water. The actual speed, range and running time may vary because of different boats, load, weather, etc.

Go with Navy

Seattle

Pike Place Market to Golden Gardens Park

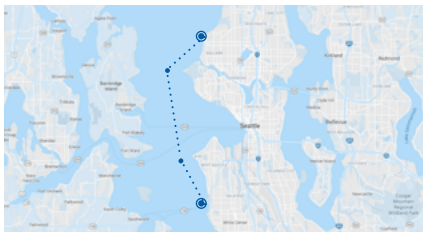

Navy 3.0 Evo + E80 = Round Trip / 38.6 km
or 24 miles

Navy 6.0 Evo + E175 = Three Trips / 57.9 km
or 36 miles

Miami

Miami Seaquarium to North Beach

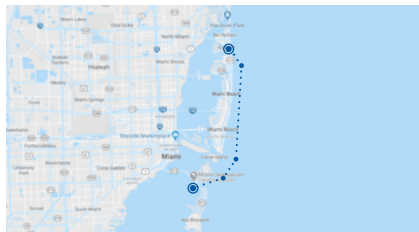

Navy 3.0 Evo + E80 = Round Trip / 35.4 km
or 22 miles

Navy 6.0 Evo + E175 = Three Trips / 53.1 km
or 33 miles

New York

Statue of Liberty to New York Aquarium



Navy 3.0 Evo + E80 = Round Trip / 35.4 km
or 22 miles

Navy 6.0 Evo + E175 = Three Trips / 53.1 km
or 33 miles

Navy 6.0 Evo Brings New Excitement

Highfield 380CL + Navy 6.0 Evo





“ With Navy 6.0 Evo, it's so quiet and so bizarre! It's just the water under the hull.

”

- Captain Rick Moore

Captain Rick Moore has been sailing for over 20 years. He has always been led by his passion and the wind, and has been sharing his sailing and adventure stories for 15 years on YouTube channel *Sophisticated Lady*.

Follow Captain Rick Moore:

-  Captain Rick Moore
-  Sailing Sophisticated Lady
-  @sailingsophisticatedlady



Watch the
review video here





X Series **New** Electric Outboard Motor



X12
12 kW

X20
20 kW

X40
40 kW

A revolutionary range, featuring an innovative, user-friendly design.

Overview

The ePropulsion X Series electric outboards are zero-emission electric propulsion system with an industry-leading powertrain efficiency of 88.2%. The X Series features a compact & fully integrated design, electric steering system, advanced driving assistance functions and connectivity service. The modular architecture not only simplifies installation but also allows for seamless integration with renewable energy sources.

Features

Compact & Fully Integrated Space-Saving Design

Narrow footprint, with no external steering gear, maximises valuable stern space, more room for boarding, swimming and socialising.



Advanced propeller design

Unparalleled hydrodynamic performance and higher efficiency.

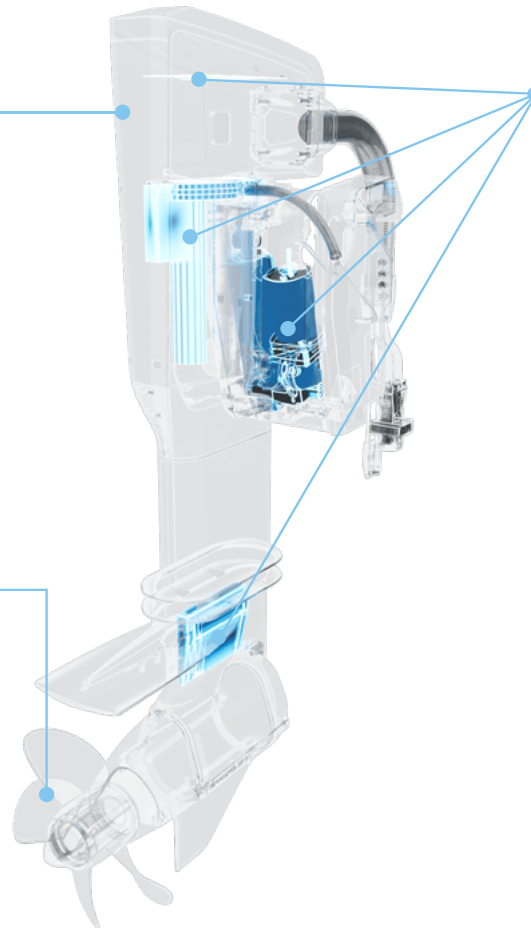

The electric steering, power trim/tilt, ECU (electric control unit), and motor controller are all integrated into one unit.

40/20/12 kW

of continuous power.

88.2%

total powertrain efficiency (excluding propeller).

Max. 36%

less weight than its conventional equivalent*.

* The weight includes the engine and the steering.



Built on state-of-the-art eSSA

Underpinned by the ePropulsion Smart System Architecture (eSSA), the X Series, eLite, I-Series, and H-Series feature a smart and modular design to deliver safe and reliable performance. It also supports the integration of ePropulsion Connectivity Service and ADAS (Advanced Driver Assistance Systems).

The modular architecture supports simple and safe connection of multiple components and enables integration with renewable energy sources, enhancing the sustainability of your boating experience.



Smart



Modular



Safe and Reliable

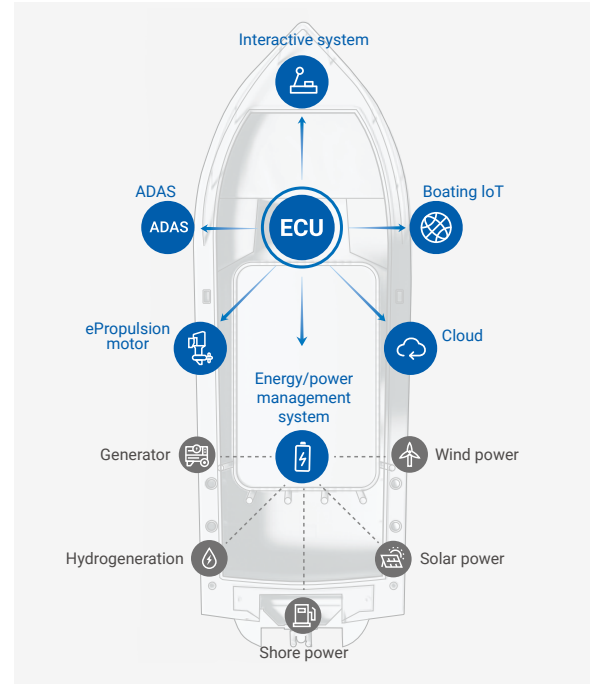

ePropulsion Connectivity Service

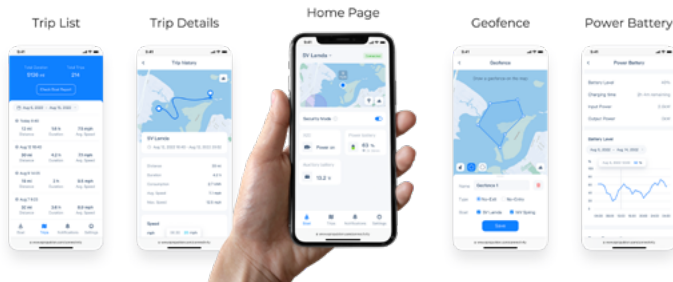

Integrated with boating IoT

ePropulsion Connectivity Service is a value-added service enabling boat owners and fleet managers to communicate with their boats securely and reliably. It allows users to access cloud-based connectivity services without the need for additional accessories.

Cutting-edge driving assistance features



Position Hold



Heading Hold

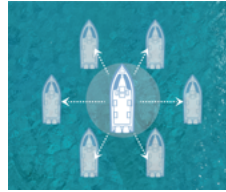

360 Motions

Thanks to advanced driver assistance systems (ADAS), the X Series enables features such as "Position Hold", "Heading Hold", and "360 Motions" for additional safety and easy control. More features to come in the future.

Key Features

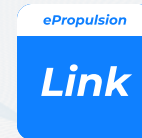

Remote data access

You can check real-time data, such as location, speed, battery level, remaining charging time, etc.



Remote monitoring

Notify users when boats break geofences, exceed speed limits, or have suspicious location changes.



Trip tracking

Automatically create boating trips with route playback and trip log.



Shared accounts

Invite other people to share access to real-time status, past activities and reports.



Guest authorization

Remotely authorize guests to power on and operate ePropulsion systems, with reduced/limited permissions if desired.



Report generation

Automatically create boat reports and fleet reports to summarise all boating activities.



Enhanced User Experience

Power trim / tilt

Comfortable and intuitive control

X Series' digital helm and smart throttles, with instant digital feedback, are responsive and easy to operate, even for boating novices.

- Streamlines installation.
- Minimises complex wiring.

Integrated electric steering

The X Series' electric steering eliminates the need for hydraulics, so it's easier to install and maintain. It also serves as a gateway to our Advanced Driving Assistance Systems, with enhanced safety and control features that revolutionise the boating experience.

A comprehensive range of accessories



- Smart Throttle
- Digital Helm
- Smart Display 5"
- Smart Display 10"
- Propellers
for different speeds or conditions
- G102-100 Battery
- MPPT Solar Charge Controller
- DC-DC Converter
- Battery Chargers
with different power capacities
- More coming soon...

Performance and Range*

	X40			X20			X12		
Input (kW)	10	20	40	5	10	20	3	6	12
Speed (km/h / mph)	12.6 / 7.8	15.4 / 9.6	35.9 / 22.3	11 / 6.8	14 / 8.7	26 / 16.2	14.5 / 9	20.4 / 12.7	30.1 / 18.7
Runtime (hh:mm)	4:00	2:00	1:00	4:00	2:00	1:00	3:20	1:40	0:50
Range (km / mi)	50.4 / 31.3	30.8 / 19.1	35.9 / 22.3	44 / 27.3	28 / 17.4	26 / 16.2	48.3 / 30	34 / 21.1	25.1 / 15.6

* The X40's performance data is based on a 20-foot V hull aluminum boat with two persons (130 kg), powered by one X40 with four G102-100 batteries (total boat weight 1030 kg), in calm lake water. The X20's performance data is based on a 14-foot V hull aluminum boat with two persons, powered by one X20 with two G102-100 batteries (total boat weight 660 kg), in calm lake water. The X12's performance data is based on a 11-foot aluminum hull inflatable boat with one person, powered by one X12 with one G102-100 battery (total boat weight 320 kg), in calm lake water.

Specs



X40 40 kW



X20 20 kW



X12 12 kW

	X40 40 kW		X20 20 kW		X12 12 kW	
	L Shaft	XL Shaft	L Shaft	XL Shaft	S Shaft	L Shaft
Motor Weight (excluding control)	104 kg (229.3 lbs)	106 kg (233.7 lbs)	79 kg (174.2 lbs)	81 kg (178.6 lbs)	48 kg (105.8 lbs)	50 kg (110.2 lbs)
Shaft Length	508 mm (20")	635 mm (25")	508 mm (20")	635 mm (25")	381 mm (15")	508 mm (20")
Dimensions (L x W x H)	757 x 360 x 1233 mm (29.8 x 14.2 x 48.5")	757 x 360 x 1360 mm (29.8 x 14.2 x 53.5")	674 x 360 x 1229 mm (26.5 x 14.2 x 48.4")	674 x 360 x 1356 mm (26.5 x 14.2 x 53.4")	560 x 266 x 978 mm (22 x 10.5 x 38.5")	560 x 266 x 1105 mm (22 x 10.5 x 43.5")
Input Power	40 kW		20 kW		12 kW	
Nominal Voltage	96 VDC		96 VDC		96 VDC	
Cooling System	Closed loop liquid cooling		Natural cooling		Natural cooling	
Rated rpm	1500 to 2100		1200 to 1800		1100 to 2000	
Trim and Tilt	Power trim/tilt		Power trim/tilt		Power trim/tilt	
Trim / Tilt Angle	-4° to 61°		-4° to 61°		-4° to 61°	
Steering	Integrated electric steering		Integrated electric steering		Integrated electric steering	
Steering Angle	±45°		±45°		±45°	
Propeller	15" x 10 3/4" propeller (available in L&R rotation) 13 3/8" x 16 3/4" propeller (available in L&R rotation)		15" x 10 3/4" propeller (available in L&R rotation) 13 3/8" x 16 3/4" propeller (available in L&R rotation)		11 13/16" x 10 5/8" propeller (available in L&R rotation) 11 7/16" x 14 3/16" propeller (available in R rotation)	



Pod Drive Series



Pod Drive 1.0 Evo
1 kW

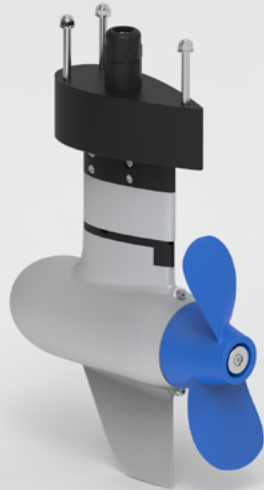

Pod Drive 3.0 Evo
3 kW



Pod Drive 6.0 Evo
6 kW



Space-Saving



Easy to Install



Quiet



Minimum Maintenance

Hydrogeneration

Sailing boat owners love the EVO series Pod Drive motors, not just because they save weight and space, but also for their hydrogeneration function... when the boat is sailing above about 4 knots, the spinning propeller and motor operate as a generator to recharge the batteries. This is environment-friendly and increases range before other means of charging are required.

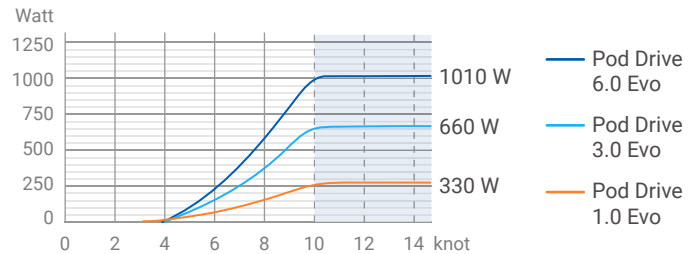

* Pod Drive 1.0 Evo, Pod Drive 3.0 Evo and Pod Drive 6.0 Evo can drive the propeller to charge the battery (only ePropulsion batteries) through water flow when certain conditions are met (please refer to the user manual in the download center for the required conditions).

Specs



Pod Drive 1.0 Evo

Pod Drive 3.0 Evo

Pod Drive 6.0 Evo

Power	1 kW	3 kW	6 kW
Operation Voltage	48 V (Input Range 39 to 60 V)		
Weight	6.2 kg / 13.7 lbs	15.3 kg / 33.7 lbs	31kg / 68.3 lbs
Static Thrust	316 N / 71 lbs	590 N / 132.6 lbs	1080 N / 242.8 lbs
Propeller rpm	1200 rpm	2300 rpm	1500 rpm
Propeller	11" x 5.8" 2-blade composite propeller	10.2" x 6.7" 2-blade composite propeller	12.6" x 8.7" 3-blade aluminum propeller / 12" x 21.3" 2-blade NAB folding propeller (optional)
Hydrogeneration	✓	✓	✓

*The weight includes the driver unit.



Pod Drive 12 eSSA

Compact, space saving, powerful, flexible & eco-friendly. Designed to propel medium sized yachts and sailboats.

New 12 kW



High Reliability

- Improved impact resistance: Crafted from high-strength aluminum alloy and subjected to rigorous collision tests.
- Effortless natural cooling: Pod Drive 12 eSSA cools itself by submerging in water, eliminating the need for cooling channels and the risk of blockages.



Hydrogeneration

Equipped with a hydrogeneration function as standard, Pod Drive 12 eSSA can charge your batteries when sailing. It will start charging from around 4 knots, and can generate up to 1400 W.

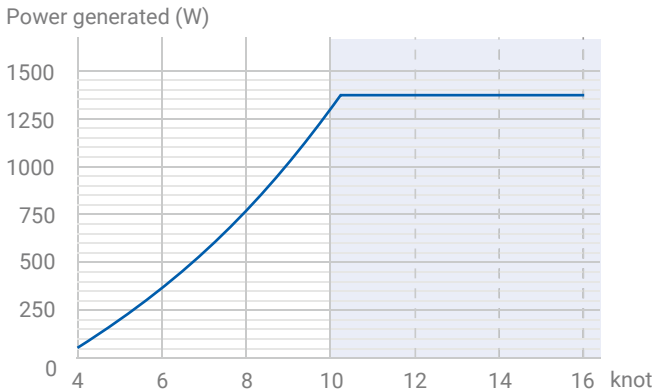

Quiet &
Clean



Smooth
running



Minimum
Maintenance



IP68
Waterproof

Space Saving

As it's an external pod drive, considerable space is saved where the diesel engine and tank(s) would normally be. Some of that is needed for the batteries and motor driver, but those components have more location options, giving designers the potential to include extra storage or larger cabins.

Easy to Install

Pod Drive 12 eSSA is a modular system, with separate motor and driver units. This makes it easy to install, and easier to upgrade in the future if the user's requirements change.

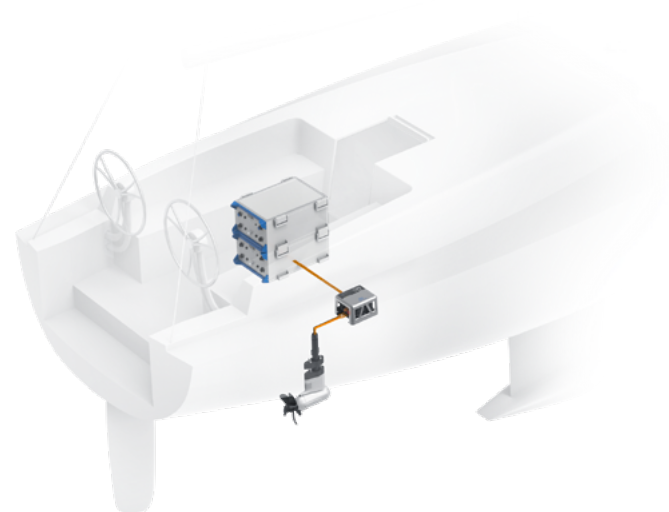



ePropulsion Link

Connectivity

The Pod Drive 12 eSSA has ePropulsion's Connectivity Service built in. This keeps you in touch with your boat's status in real time, including monitoring, reporting, and trip tracking functions.

Smart and User-friendly Control System

The HMI system, Smart Throttle and Smart Display 5" offer intuitive, fingertip control and comprehensive information at the helm.

NMEA 2000 Compatible

The NMEA 2000 interface allows integration with other multifunction displays (MFDs).



Performance and Range*

Input (kW)	3	6	9	12
Speed (km/h / mph)	7.8 / 4.8	10.3 / 6.4	11.6 / 7.2	12.1 / 7.5
Runtime (hh:mm)	3:20	1:40	1:06	0:50
Range (km / mi)	26 / 16.1	17.2 / 10.7	12.9 / 8.1	10.1 / 6.2

* The performance data is based on a 30-foot shallow draft sailboat with 4250 kg displacement, powered by one Pod Drive 12 eSSA with one G102-100 battery in calm lake water.

Flexible & Scalable

The Pod Drive 12 eSSA is ideal for both custom-designed new boat installation and for retrofitting old boats. Different numbers of batteries can be selected according to the speed and range requirements (Up to 8 batteries can be connected in parallel within a single cluster. Multiple clusters are possible in the system).

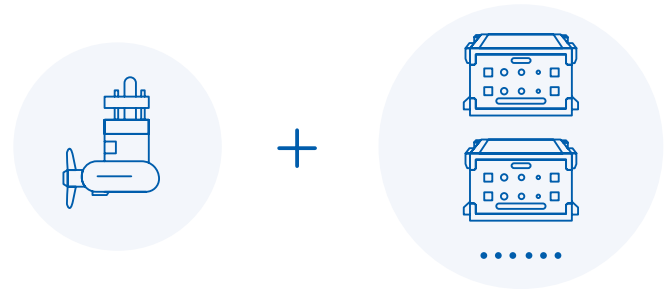

G102-100 Battery

Runtime with 1 x G102-100 battery

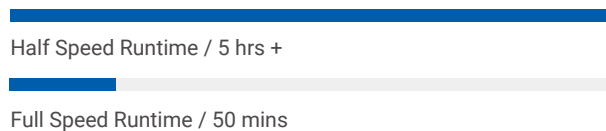

Runtime with 2 x G102-100 batteries

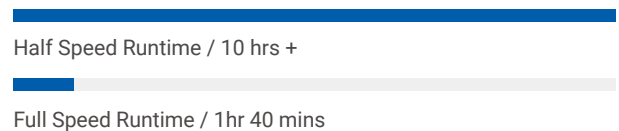

Specs

Input Power	12 kW
Nominal Voltage	96 VDC
Weight (driver unit included)	35 kg (77.2 lbs)
Dimensions (L x W x H)	Motor: 424 x 300 x 750 mm (16.7 x 11.8 x 29.5") Driver unit: 274 x 221 x 167 mm (10.8 x 8.7 x 6.6")
Cooling System	Motor: Natural cooling Driver unit: Air cooling
Rated rpm	1400 to 2100
Propeller	11 4/5" x 9 4/5" propeller (available in L&R rotation) 13" x 9 3/4" folding propeller

* The specifications are for reference only.



I-Series Electric Inboard Motor

Bringing the benefits of electrification and intelligent connectivity to small and medium-sized boats.

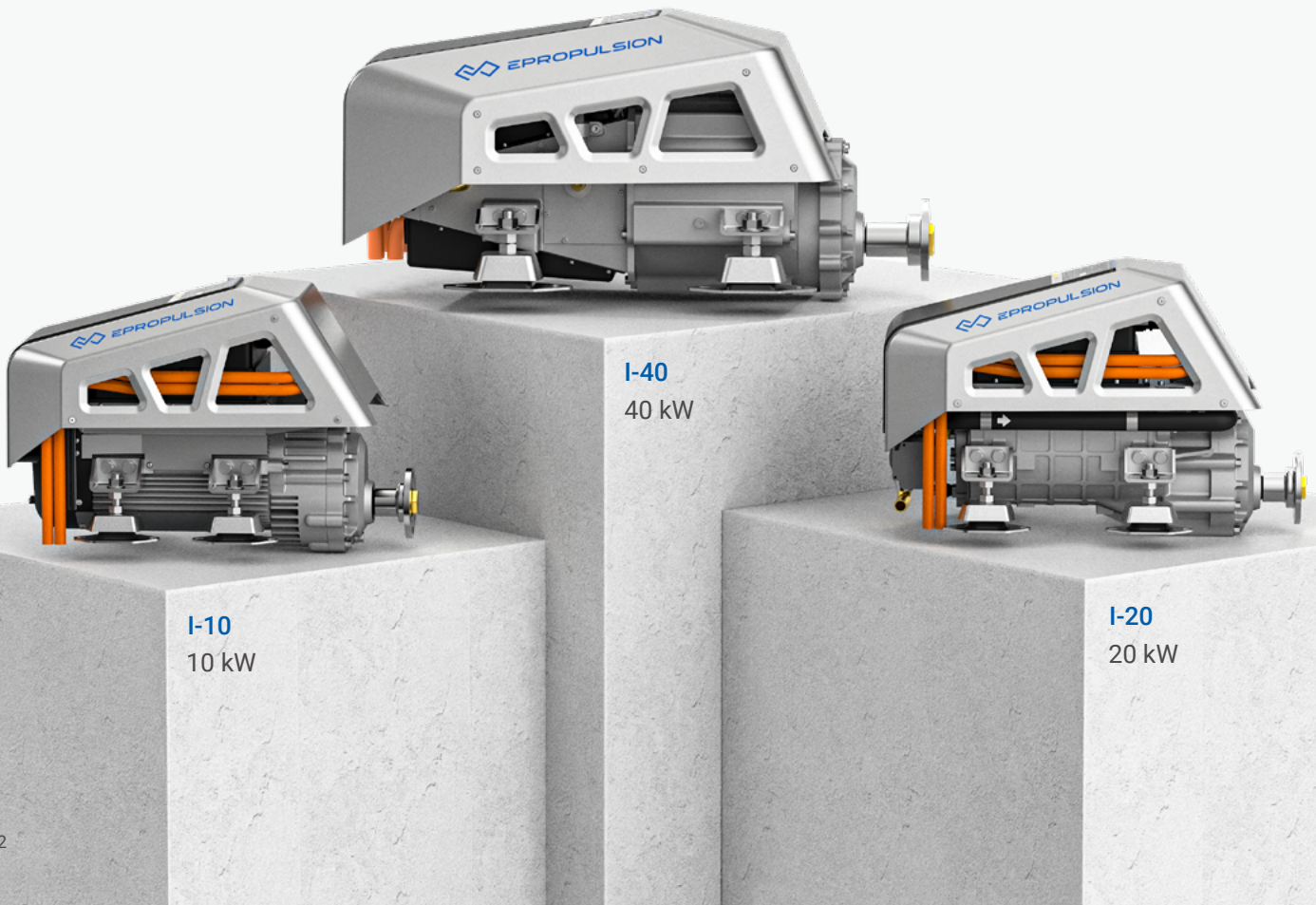

Overview

ePropulsion's I-series electric inboard motors are friendly to both the environment and their operators, combining zero emissions with innovative and intuitive technology. At the system's core, eSSA (ePropulsion Smart System Architecture) plus IoT (Internet of Things) connectivity provide users with an easy-to-use, intelligent, safe and reliable experience. They are ideal for leisure marine and commercial applications on small and medium size boats including cruisers, workboats, ferries, water buses, monohull sailboats and catamaran sailboats, etc.

Features



Efficient



Clean



Quiet



Hydrogeneration



Compact and Integrated

Compact design that integrates five functional modules of motor, gearbox, motor controller, system control unit and cooling system into a single unit.

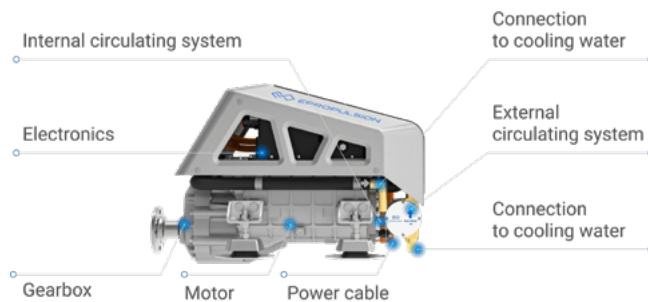

Space-saving

Take up 60% less space than typical combustion engines and reduce engine room size.*



Lighter weight

65% less weight than typical combustion engines and 30% lighter than electric inboard motors of similar power.*



Easy to install

Internal wiring has been connected before delivery, providing customers with an out-of-the-box experience.



Easy to maintain

The technology and the design of the interfaces offer significantly lower maintenance than combustion engines.

* Under the same input power.



Built on state-of-the-art eSSA

Underpinned by the ePropulsion Smart System Architecture (eSSA), the I-Series features a smart and modular design to deliver safe and reliable performance. It also supports the integration of ePropulsion Connectivity Service and ADAS (Advanced Driver Assistance Systems).



Smart



Modular



Safe and Reliable

Integrated with boating IoT

ePropulsion Connectivity Service is a value-added service enabling boat owners and fleet managers to communicate with their boats securely and reliably. It allows users to access cloud-based connectivity services without the need for additional accessories.

Specs



Model	I-10	I-20	I-40
Input power	10 kW	20 kW	40 kW
Input voltage	86 to 115 VDC	86 to 115 VDC	86 to 115 VDC
Weight	45 kg	49.5 kg	93 kg
Dimensions (L x W x H)	565 x 295 x 380 mm	580 x 330 x 380 mm	667 x 452 x 477 mm
Cooling method	Air cooling	Water cooling (air cooling optional)	Water cooling (air cooling optional)
Rated rpm	1200 to 1700	1200 to 1700	900 to 1500
Operation and interaction	Throttle & display	Throttle & display	Throttle & display
Connectivity service	Support	Support	Support

* The specifications are for reference only.

Accessories

Standard accessories

The Smart Throttle and Smart Display 5" provide excellent user experience in controlling and monitoring. There are three mounting options for the smart throttle, so that you can find the best fit for your boat.

Smart Throttle



- ✓ Top or Side
- ✓ Single or Dual
- ✓ Portside or Starboard

* More control methods are coming...

Smart Display 5"



- Designed for marine environment
- Local cloud interconnection
- Data synchronization
- Intelligent diagnosis
- Active interaction
- High security

External GPS Module, 4G Antenna, DC-DC, Busbar and Cable Kits are optional.

OEM accessories upon request

Propeller, air-cooling, HVAC system, shaft and coupling, chargers and more to come...



H-Series Electric Inboard Motor

60 to 250 kW

Modular Design

OEM Capability

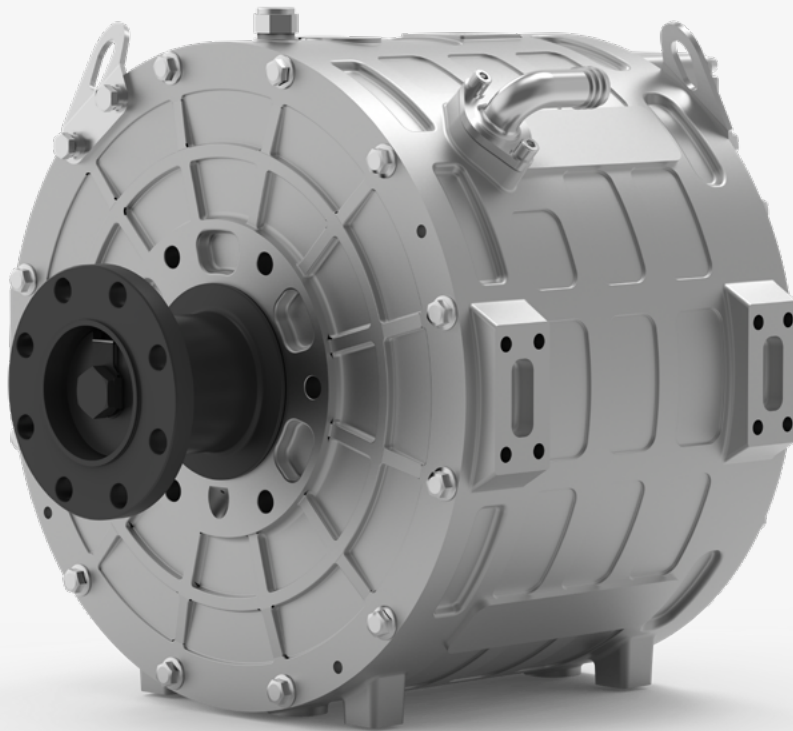

Overview

H-Series inboard motors are engineered for larger sailing boats and motor vessels between 60 and 100' (18 to 30 m) with a full displacement up to 200 tons. It delivers high performance with very low noise and vibration, and zero exhaust fumes.

- ① H-Series electric inboard motor
- ② Remote control and display
- ③ Controller
- ④ Battery

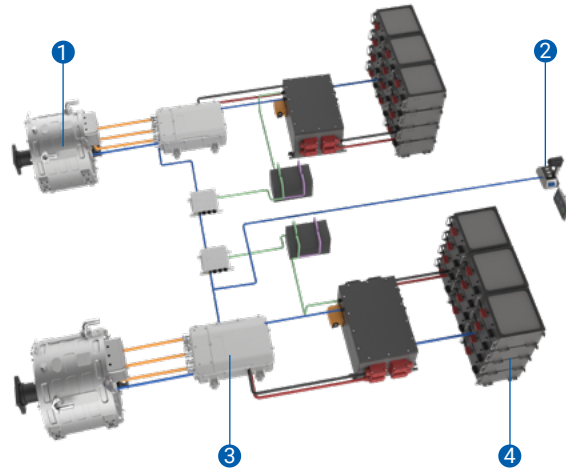

Specs

	H-60	H-85	H-100	H-140
Rated Voltage	540 VDC	540 VDC	540 VDC	540 VDC
Rated Power	60 kW	85 kW	100 kW	140 kW
Rated Torque	478 Nm	779 Nm	797 Nm	1121 Nm
Rated Speed	1150 rpm	1000 rpm	1150 rpm	1145 rpm
Weight	110 kg	150 kg	190 kg	250 kg
Dimensions	336 x 285 mm (13.2 x 11.2 in)	336 x 380 mm (13.2 x 15.0 in)	443 x 315 mm (17.4 x 12.4 in)	443 x 387 mm (17.4 x 15.2 in)
Rated Efficiency	96%	96%	96%	96%
Insulation Level	H	H	H	H
Cooling Methods	Water Cooling	Water Cooling	Water Cooling	Water Cooling
Operating Temperature	-25 to 55°C	-25 to 55°C	-25 to 55°C	-25 to 55°C
IP Rating	IP67	IP67	IP67	IP67



Features

Smaller size, better space utilization

H-Series is about two-thirds lighter and 50% smaller than its diesel counterpart, providing installation flexibility and maximizing payload and passenger space. The flat wire motor increases slot fill by 25% and increases power density.

Modular design, high expandability

H-Series electric inboard motor kit adopts modular design. The manufacturers can easily extend the range and power by adding motors, controllers and batteries, and having more flexibility. Different power combinations can be chosen according to different power and range requirements, which allows the H-100 to be more expandable.

Optimum performance, pioneering technology

Equipped with pioneering permanent magnet motor technology, the H-Series gives its diesel counterparts a run for their money, achieving 2000 Nm maximum torque and delivering an impressive 96% efficiency, higher than the traditional 100 kW AC asynchronous motor.



Boating IoT system, smart and customizable

The boating Internet of Things (IoT) system can be customized and developed to meet the customers' needs of remote monitoring and integrated management. Speed, power, track, mileage, safety alarm and other functions also can be customized and developed according to your requirements. Boat owners can use the web port to track their boats in real time and to realize integrated management.

Safety and reliability

- IP67 waterproofing
- Anti-corrosion
- High accuracy position feedback
- High torque density
- Closed-loop cooling

Accessories

Custom-built Battery

Battery can be tailored to fit customers' needs. The battery power needs to be calculated and determined according to the range requirements. For a 100 kW electric inboard motor operating at full power for 1 hour, the propulsion system will need a 100 kWh battery which can be developed based on the provided specs.

System Rated Output Voltage	540 VDC	Discharge Temperature	-10 to 60°C
System Output Voltage Range	487 to 604 VDC	25°C Cycle Life (80% DOD)	> 3500 times
Battery Capacity **	/	25°C Storage Life	> 8 years
Total System Energy **	/	Charging Temperature	0 to 55°C

* The battery specifications are based on a 100 kW electric inboard motor operating at full power for 1 hour. Actual performance parameters may vary depending on battery capacity.

** Battery capacity and total system energy can be customized to fit customers' needs.

Controller



Logic Power Supply Range	9 to 16 V	Rated Output Current	270 A
Rated Input Voltage	540 VDC	Maximum Efficiency	98%
Input Voltage Range	400 to 720 VDC	IP Rating	IP67
Rated Power	160 kVA		

Smart and user-friendly control system

The HMI system, Smart Throttle and Smart Display 5" provide excellent user experience in controlling and monitoring.





E-Series Lithium Battery

Safe and durable LiFePO4 batteries for ePropulsion motors.



E163
8345 Wh

E60
3072 Wh

Overview

ePropulsion motors are optimised when connected to ePropulsion batteries... a one-make system eliminates compatibility issues and provides more data to the user. The 48 V E-Series batteries work seamlessly with all ePropulsion 48 V motors (Spirit, Navy, Evo), and use LifePO4 (lithium iron phosphate) chemistry, which is safe, stable and long-lasting (retaining over 80% capacity after 3000 charge cycles). E-Series are much more compact and lightweight than lead acid batteries, making it easier to install sufficient capacity in a convenient space.

Why Choose E-Series Battery



Competitive cost

Unit price of E-Series batteries are as low as about \$0.5 per watt-hour.



Long life cycles

3000 cycles at 80% DOD.



High energy density

70% less weight and space than a normal lead-acid battery *



Made for ePropulsion motors

Data is synced with ePropulsion motors to allow a smart operation strategy.



Data accuracy

ePropulsion batteries are designed for maximum efficiency, performance and safety. They allow for the use of our communication cable which brings data accuracy to the gauge and ensures a useful operating strategy for safety and performance.

*Under equal capacity.



Features

 **1C Rate Fast Charging**

 **Waterproof to IP67**

 **CE, UKCA, FCC, and UN38.3 Certification**

E60

3072 Wh / 48 V



High Performance

E60 (single battery) can support Navy 3.0 Evo (3 kW) full power output.

Flexible Installation

The height of E60 battery is only 300 mm, allowing flexible installation under the boat seat or other available spaces.

Lightweight

Features a new innovative double-layer plastic housing design weighing only 33 kg and can be safely lifted by a person.

E163

8345 Wh / 48 V



High Performance

E163 (single battery) can support Navy 6.0 Evo (6 kW) full power output.

High Reliability

All-metal housing is more reliable, weather resistant, impact resistant and drop proof.

Design

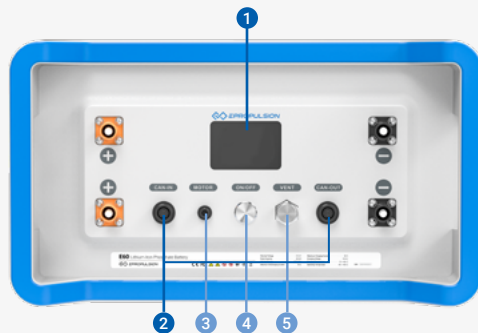

- 1 HD Screen
- 2 CAN communication port
- 3 Motor communication port
- 4 Power button
- 5 Vent valve

Specs

	E60	E163
Capacity	3072 Wh / 60 Ah	8345 Wh / 163 Ah
Rated Voltage	51.2 V	51.2 V
Battery Life	3,000 cycles at 80% DOD	3,000 cycles at 80% DOD
Weight	33 kg	76 kg
Cut-off Voltage	41.6 V	41.6 V
Final Charging Voltage	57.6 V	57.6 V
Serial Connection	N/A	N/A
Max Continuous Discharging Current	70 A	150 A
Parallel Connection	Up to 16	Up to 16
Cell Configuration	16S4P	16S1P
Charger	E-Series battery charger	E-Series battery charger
Charging Time (220 V)	One charger: 2.7 hrs Two chargers in parallel: 1.3 hrs	One charger: 7.2 hrs Two chargers in parallel: 3.6 hrs
Charging Time (110 V)	One charger: 4 hrs Two chargers in parallel: 2 hrs	One charger: 11 hrs Two chargers in parallel: 5.4 hrs
Charging Temperature	0 to 55°C (32 to 131°F)	0 to 55°C (32 to 131°F)
Discharging Temperature	-10 to 60°C (14 to 140°F)	-10 to 60°C (14 to 140°F)
Shipping Classification	UN3480, Class 9, UN38.3 Certified	UN3480, Class 9, UN38.3 Certified
Certifications	CE, UKCA, FCC	CE, UKCA, FCC



G102-100

Lithium Iron Phosphate Battery (LiFePO₄)

High-performance and durable lithium battery for electric boating



10240 Wh / 96 V



1C Rate
Fast Charging



Waterproof
to IP67



CE, UKCA, FCC,
UN38.3 Certification

Features



Fully Compatible with ePropulsion Motors

Power the 96 V 10 kW to 40 kW ePropulsion motors including the I-Series inboards.*



Long Life Cycle

3,000 cycles at 80% DOD, the G102-100 lifepo4 battery powers your motors much longer than lead-acid batteries.**



Easy to Install

Connectors can be installed with only ONE hand, and the battery saves wiring harness connection compared to series-parallel connection of battery.



Maximum Safety

Made with LFP, the built-in intelligent battery management system (BMS) is applied to provide maximum safety for the users.



High Energy Density

3 times higher energy density and 70% less weight than lead-acid batteries.**



High Reliability

All-metal housing is more reliable, weather resistant, impact resistant and drop proof.

* G102-100 can be connected in parallel to power different ePropulsion motors.

** Under equal capacity.

Specs

Rated Voltage	102.4 V	Cell Configuration	32S1P
Cut-off Voltage	83.2 V	Charging Temperature	0 to 55°C
Final Charging Voltage	115.2 V	Discharging Temperature	-10 to 60°C
Serial Connection	N/A	Dimensions	680 x 500 x 300 mm (26.8 x 19.7 x 11.8 in)
Max Continuous Discharging Current	100 A	Weight	100 kg
Battery Life	3,000 cycles at 80% DOD	Shipping Classification	UN3480, Class 9, UN38.3 Certified
Parallel Connection	Up to 8 in 1 cluster. Multiple clusters are possible in the system	Communication	One CAN for ePropulsion motors / One CAN (Two ports) for parallel batteries / One CAN for charger



Accessories

We strive to provide the highest quality accessories to enhance your boating experience. The full range of ePropulsion accessories and details are available at <https://www.epropulsion.com/accessories/>

Controls

Digital Helm



Smart Throttle



Smart Display 5"



Smart Display 10"



Evo Tiller



Evo Remote Control



Controls

Evo Side Mount Control



Evo Dual Remote Control



E Battery External Display Panel



Charging

Spirit 1.0 Plus Charger



Spirit 1.0 Plus 12 V Charger



Spirit 1.0 Plus Solar Charger



Charging

Spirit 1.0 Plus
Fast Charger



E Battery Charger 25 A



Foldable
Solar Panel



Propellers

Spirit 1.0
Propeller

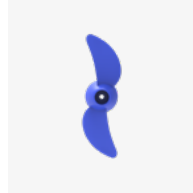

Navy 3.0
Propeller

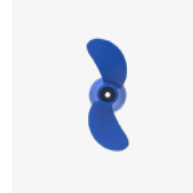

Navy 6.0 Low Pitch
Propeller



Propellers

Navy 6.0 High Pitch
Propeller



Navy 6.0 Evo AL
Propeller



Pod 1.0 Evo Folding
Propeller



Pod 3.0 Evo Folding
Propeller



Pod 6.0 Evo Folding
Propeller



Pod 6.0 Evo
Propeller

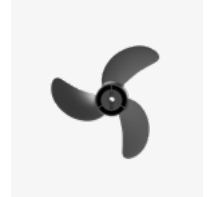

Propellers

X12 Low Pitch
Propeller

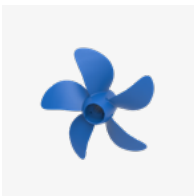

X12 High Pitch
Propeller

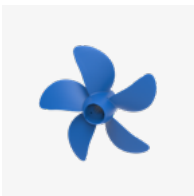

X20 / X40 Low Pitch
Propeller



X20 / X40 High Pitch
Propeller

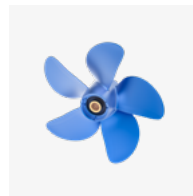

Bags

eLite Carrying
Bag



Spirit 1.0 Outboard Bag
Plus & Battery Bag





Online ePropulsion Owner Community

We connect and engage ePropulsion owners from all around the world through the Official ePropulsion Outboard Owners Facebook Group.

Join us and share your exciting electric boating moments with the worldwide ePropulsion customers. You will also get fast responses when you have questions about your ePropulsion products as well as staying updated on product upgrade and promotions.

Most active members will be recognized and be rewarded with souvenirs such as branded apparel and headwear.



Search **Official ePropulsion Outboard Owners** on Facebook



MOTORS

PART NO	PRODUCT	DESCRIPTION
SPIRIT		
SP-0000-X1	Spirit 1.0 Plus Extra Shortshaft	1 kW direct drive electric outboard motor, including a 1276 Wh battery, an integrated tiller and a charger. Shaft length 52.5 cm / 20.7 in.
SP-0000-S1	Spirit 1.0 Plus Shortshaft	Same as above with different shaft length 62.5 cm / 24.6 in.
SP-0000-L1	Spirit 1.0 Plus Longshaft	Same as above with different shaft length 75 cm / 29.5 in.
SP-1111-X1	Spirit 1.0 Plus Extra Shortshaft w/o Battery	1 kW direct drive electric outboard motor, including a tiller and a charger. Battery is excluded. Shaft length 52.5 cm / 20.7 in.
SP-1111-S1	Spirit 1.0 Plus Shortshaft w/o Battery	Same as above with different shaft length 62.5 cm / 24.6 in.
SP-1111-L1	Spirit 1.0 Plus Longshaft w/o Battery	Same as above with different shaft length 75 cm / 29.5 in.
SE-TTTT-S0	Spirit 1.0 Evo Shortshaft	1 kW direct drive electric outboard motor featuring hydrogeneration including a 1276 Wh battery, a detachable tiller and a charger. Shaft length 62.5 cm / 24.6 in.
SE-TTTT-L0	Spirit 1.0 Evo Longshaft	Same as above with different shaft length 75 cm / 29.5 in.
SE-RRRR-S0	Spirit 1.0 Evo Remote Shortshaft	1 kW direct drive electric outboard motor featuring hydrogeneration including a 1276 Wh battery, a remote control, a charger and a remote kit. Shaft length 62.5 cm / 24.6 in.
SE-RRRR-L0	Spirit 1.0 Evo Remote Longshaft	Same as above with different shaft length 75 cm / 29.5 in.
SE-1111-S0	Spirit 1.0 Evo Motor Body Shortshaft	1 kW direct drive electric outboard motor featuring hydrogeneration. Battery and control are excluded. Shaft length 62.5 cm / 24.6 in.
SE-1111-L0	Spirit 1.0 Evo Motor Body Longshaft	Same as above with different shaft length 75 cm / 29.5 in.
SE-R999-00	Spirit 1.0 Evo Remote Kit	This remote kit helps you turn a Spirit 1.0 Evo motor into a remote version that works with a steering wheel.
NAVY		
NE-3000-S0	Navy 3.0 Evo Shortshaft	3 kW direct drive electric outboard motor featuring hydrogeneration. Battery, control and charger are excluded. Shaft length 64 cm / 25.2 in.
NE-3000-L0	Navy 3.0 Evo Longshaft	Same as above with different shaft length 76.5 cm / 30.1 in.
NE-6000-S1	NAVY 6.0 Evo (2024) Shortshaft	6 kW direct drive electric outboard motor featuring hydrogeneration. Battery, control and charger are excluded. Shaft length 64 cm / 25.2 in.
NE-6000-L1	NAVY 6.0 Evo (2024) Longshaft	Same as above with different shaft length 76.5 cm / 30.1 in.



PART NO	PRODUCT	DESCRIPTION
POD		
P1-0000-E0	Pod Drive 1.0 Evo	1 kW direct drive electric pod drive motor featuring hydrogeneration. Battery, control and charger are excluded.
P3-0000-E0	Pod Drive 3.0 Evo	3 kW direct drive electric pod drive motor featuring hydrogeneration. Battery, control and charger are excluded.
P6-0000-E0	Pod Drive 6.0 Evo	6 kW direct drive electric pod drive motor featuring hydrogeneration. Battery, control and charger are excluded.
PA-0000-00	Pod Drive 12 eSSA	12 kW direct drive electric pod drive motor featuring hydrogeneration. Battery, control and charger are excluded.

I SERIES INBOARD

A1-0000-01	I-10 Electric Inboard Motor	Electric inboard motor with a rated power of 10 kW.
A2-0000-01	I-20 Electric Inboard Motor	Electric inboard motor with a rated power of 20 kW.
A4-0000-00	I-40 Electric Inboard Motor	Electric inboard motor with a rated power of 40 kW.

X SERIES OUTBOARD

X1-0000-S0	X12 Electric Outboard Motor-S	Electric outboard motor with a rated power of 12 kW. Battery, control and charger are excluded. Shaft length 38.1 cm / 15 in.
X1-0000-L0	X12 Electric Outboard Motor-L	Electric outboard motor with a rated power of 12 kW. Battery, control and charger are excluded. Shaft length 50.8 cm / 20 in.
X2-0000-L0	X20 Electric Outboard Motor-L	Electric outboard motor with a rated power of 20 kW. Battery, control and charger are excluded. Shaft length 50.8 cm / 20 in.
X2-0000-X0	X20 Electric Outboard Motor-XL	Electric outboard motor with a rated power of 20 kW. Battery, control and charger are excluded. Shaft length 63.5 cm / 25 in.
X4-0000-L0	X40 Electric Outboard Motor-L	Electric outboard motor with a rated power of 40 kW. Battery, control and charger are excluded. Shaft length 50.8 cm / 20 in.
X4-0000-X0	X40 Electric Outboard Motor-XL	Electric outboard motor with a rated power of 40 kW. Battery, control and charger are excluded. Shaft length 63.5 cm / 25 in.

VAQUITA

VA-0000-00	Vaquita	300 W direct drive electric SUP motor, including a 324 Wh battery, a remote control and a charger.
------------	---------	--

eLite OUTBOARD

EL-0500-00	eLite Electric Outboard Motor	Electric outboard motor with a max input power of 750 W(Sport Mode) and a rated power of 500 W, including a 378 Wh battery, an integrated display, a foldable and extendable tiller and a charger. Shaft length can be adjust between 28.25 cm / 11.12 in to 40.1 cm / 15.8 in.
------------	-------------------------------	---

BATTERIES

PART NO	PRODUCT	DESCRIPTION
SP-B000-02	Spirit Battery Plus	1276 Wh / 48 V lithium battery for Spirit series outboard motors.
EB-0060-00	E60 Battery	3072 Wh / 48 V LiFePO4 battery with 3000 cycles of battery life.
EB-0163-00	E163 Battery	8345 Wh / 48 V LiFePO4 battery with 3000 cycles of battery life.
GB-0100-01	G102-100 Battery	10240 Wh / 96 V LiFePO4 battery with 3000 cycles of battery life.
VA-B000-00	VAQUITA Battery	324 Wh / 21.6 V lithium battery for Vaquita motor.

CONTROLS

PART NO	PRODUCT	DESCRIPTION
NE-TC00-00	Evo Tiller	Detachable tiller with integrated display monitoring real-time motor / battery status, for Spirit Evo models and Navy Evo models.
NE-RC00-00	Evo Remote Control	Remote control with an integrated display for Spirit 1.0 Evo Remote, Navy Evo models and Pod Drive Evo models.
NE-SM00-00	Evo Side Mount Control	Side mount control with an independent display for Spirit 1.0 Evo Remote, Navy Evo models and Pod Drive Evo models.
NE-DR00-00	Evo Dual Remote Control	Two-throttle remote control designed for twin installations of Spirit 1.0 Evo Remote, Navy Evo models, and Pod Drive Evo models. It comes with an independent display.
XS-RC00-00	Smart Throttle	Wired remote control for X-Series outboard motors, I-Series inboard motors and Pod Drive eSSA models.
XS-DP00-00	Smart Display 5"	Display panel for X-Series outboard motors, I-Series inboard motors and Pod Drive eSSA models.
VA-RC00-00	Vaquita Remote Control	Wireless remote control for Vaquita SUP motor. 8 forward speeds. Overboard protection.



ACCESSORIES

PART NO	PRODUCT	DESCRIPTION
CHARGERS & SOLAR PANEL		
VA-C000-00	Vaquita Charger	180 W charger for Vaquita Battery. Input voltage (AC): 100 to 240 V.
EL-C001-00	eLite Charger	117 W charger for eLite. Input voltage (AC): 100 to 240 V.
EL-C002-00	eLite 12 V Charger	60 W DC-DC charger, allowing the eLite to be charged from a 12 V cigarette lighter power socket.
EL-C003-00	eLite Solar Charger	100 W solar charger with MC4 connector.
SP-C001-00	SPIRIT 1.0 Plus Charger	180 W charger for Spirit Battery Plus. Input voltage (AC): 100 to 240 V.
SP-C002-00	SPIRIT 1.0 Plus 12 V Charger	70 W DC-DC charger, allowing a Spirit Battery Plus to be charged from a 12 V cigarette lighter power socket.
SP-C003-00	SPIRIT 1.0 Plus Solar Charger	180 W solar charger with MC4 connector.
SP-C004-02	SPIRIT 1.0 Plus Fast Charger	520 W fast charger. Input voltage (AC): 100 - 240 V.
EC-0025-00	E Battery Charger 25 A	For E-Series battery. Max output current (220 V): approx. 25 A. Parallel connection: max 8 units.
EC-0025-00	E Battery Charger 25 A	For E-Series battery. Max output current (110 V): approx. 15 A. Parallel connection: max 8 units.
GB-C001-00	G Battery Charger 16 A	For G-Series battery. Max input current (both 110 V / 220 V): approx. 16 A.
EB-C002-00	E Battery MPPT Solar Charger Controller 1.6 kW	1600 W solar charger, allowing the E battery to be charged with solar energy (solar panel excluded).
GB-C002-00	G Battery MPPT Solar Charger Controller 2 kW	2000 W solar charger, allowing the G battery to be charged with solar energy (solar panel excluded).
FS-P000-00	Foldable Solar Panel	100 W foldable solar panel, designed for the solar charger of Spirit Battery Plus and eLite.

PART NO	PRODUCT	DESCRIPTION
CABLES		
00-0601-04	Spirit/Navy Communication Cable 0.5 m	Connect an Evo motor to either an Evo control or an E-Series battery.
00-0601-01	Spirit/Navy Communication Cable 5 m	Connect an Evo motor to either an Evo control or an E-Series battery.
00-0601-03	Spirit/Navy Communication Extension Cable 5 m	Extend the 5-meter communication cable by an additional 5 meters to enable wired operation from an extended distance.

PART NO	PRODUCT	DESCRIPTION
EB-AC01-01	Battery Communication Terminator	This is a required item for the parallel connection of E60 & E163 & G-Series batteries. It connects to the CAN-IN on the master battery and CAN-OUT port on the end battery.
EB-AC02-01	Battery Remote Switch 5 m	This switch with a 5 m cable allows you to switch on/off paralleled E60, E163 and G series batteries in a distance. It connects to the CAN-IN port.
EB-AC05-00	Battery Comm Cable T Connector	A CAN T connector with one male connector and two female connectors, allowing you to connect both the control and the E60 & E163 batteries to an ePropulsion motor.
EB-CP09-00	E Battery Bridging Cable 0.15 m (Positive & Negative)	For E60 & E163 batteries parallel connection.
EB-CP01-00	E Battery Bridging Cable 0.45 m (Positive & Negative)	For E60 & E163 batteries parallel connection.
EB-CP02-00	E Battery Bridging Cable 1.5 m (Positive & Negative)	For E60 & E163 batteries parallel connection.
EB-CP03-00	E Battery Bridging Cable 5 m (Positive & Negative)	For E60 & E163 batteries parallel connection.
EB-CP04-00	E Battery Output Cable 1.5 m (Positive & Negative)	For E60 & E163 batteries and motor connection.
EB-CP05-00	E Battery Power Cable Connector	For E60 & E163 batteries and motor connection.
EB-CP10-00	Battery Communication Cable Kit 0.5 m	A 0.5 m communication cable used for parallel connection between E-Series batteries or G-Series batteries.
EB-CP11-00	Battery Communication Cable Kit 1.5 m	A 1.5 m communication cable used for parallel connection between E-Series batteries or G-Series batteries.
EB-CP12-00	Battery Communication Cable Kit 5 m	A 5.0 m communication cable used for parallel connection between E-Series batteries or G-Series batteries.
00-0603-14	G Battery Output Cable Kit 10 m (Positive & Negative)	For G-Series batteries and motor connection.
GB-CP01-01	G Battery Bridging Cable 0.5 m (Positive & Negative)	For G-Series batteries parallel connection.
GB-CP02-01	G Battery Bridging Cable 1.5 m (Positive & Negative)	For G-Series batteries parallel connection.
GB-CP03-01	G Battery Bridging Cable 5 m (Positive & Negative)	For G-Series batteries parallel connection.
00-0601-08	SPIRIT External Battery Cable 1.5 m	This cable allows you to connect the Spirit 1.0 Plus/Evo motor with a 48 V E-Series Battery to extend range.
00-0601-09	SPIRIT 1.0 Plus Extension Power Cable 2 m	It connects the Spirit Battery Plus and the Spirit 1.0 Plus/Evo motor, allowing you to place the battery 2 meters from the motor.
00-0601-12	Spirit/Navy Y Type Communication Cable 0.3 m	A communication cable with one male connector and two female connectors, allowing you to connect both the Control and the E-Series batteries to an ePropulsion motor.
00-0603-09	ESSA Communication 5-way T Connector	Two connectors for backbone connections and three for adding dropline devices.
00-0603-01	ESSA Communication 3-way T Connector	Two connectors for backbone connections and one for adding dropline device.



PART NO	PRODUCT	DESCRIPTION
00-0603-10	ESSA Communication Terminator 120 Ω	A communication terminator must be present at the two physical end points of the eSSA network.
00-0603-11	ESSA Communication Terminator 360 Ω	A communication terminator must be present at the two physical end points of the eSSA network.
00-0603-08	ESSA Communication Extension Cable 5 m	One male and one female connector.
00-0603-07	ESSA Communication Extension Cable 10 m	One male and one female connector.
00-0603-06	ESSA Communication Cable 1 m	Two female connectors.
00-0601-25	Connection Cable for Pod 1.0 Evo and Spirit Battery Plus 1 m	It connects the Spirit Battery Plus and the Pod Drive 1.0 Evo.
NE-TC01-L0	EVO/Plus Tiller Extensions 60 cm	For the tiller extension. Applies to Spirit 1.0 Plus/Evo.
00-0601-70	E Battery Charger Y Type Communication Cable 0.5 m	For multiple E battery chargers to charge the battery.

STEERING

00-0800-02	Dual Motor Link Arm 700 to 900 mm	For dual-outboard steering.
00-0800-03	Dual Motor Link Arm 400 to 600 mm	For dual-outboard steering.
SR-CM04-00	Link Arm Lock	For locking the steering link arm.
XS-SW00-A0	Digital Helm	For X series outboard steering. A steering wheel included.

PROPELLERS, SKEGS, ANODES

S1-M001-00	SPIRIT 1.0 Propeller	11" x 5.8" 2-blade composite propeller, applies to Spirit 1.0 Plus/Evo.
SE-TB01-00	SPIRIT 1.0 EVO Clamp Anode	Applies to Spirit Plus manufactured since 2022 and Spirit Evo.
S1-TB02-05	SPIRIT 1.0 Clamp Base Anode	Applies to all Spirit outboards.
SP-M013-00	SPIRIT 1.0 Plus Motor Anode	Applies to Spirit 1.0 Plus/Evo.
SP-M012-00	SPIRIT 1.0 Plus Shaft Anode	Applies to Spirit 1.0 Plus/Evo.

PROPELLERS, SKEGS, ANODES		
S1-TB03-06	SPIRIT 1.0 Trapezoidal Anode	Applies to Spirit 1.0 Plus/Evo.
N6-AP00-E0	NAVY 6.0 Evo Anticavitation Plate	Made of high-strength aluminum alloy.
N6-TB11-00	NAVY Clamp Anode	Applies to Navy, Evo, double inner-side of clamp.
N6-AP00-00	NAVY Anticavitation Plate	Made of high-strength aluminum alloy.
N6-LU01-00	NAVY Anode	Applies to Navy Evo, outside of the propeller shaft.
P6-M013-00	NAVY EVO Anode	Applies to Navy 6.0 Evo & Pod 6.0 Evo.
N3-LU05-00	NAVY 3.0 Propeller	10.2" × 6.7" 2-blade composite propeller.
N6-LU02-00	NAVY 6.0 Low Pitch Propeller	13.4" × 8.5" 3-blade composite propeller.
N6-LU12-00	NAVY 6.0 High Pitch Propeller	12.6" × 10.8" 3-blade composite propeller.
N6-LU01-E0	NAVY 6.0 Evo AL Propeller	12.6" × 8.7" 3-blade aluminum propeller.
P6-M001-00	Pod 6.0 Evo Propeller	12.6" × 8.7" 3-blade aluminum propeller.
P6-LU01-00	Pod 6.0 Evo Folding Propeller	12" × 21.3" 2-blade NAB folding propeller.
P3-LU01-E0	Pod 3.0 Evo Folding Propeller	9.96" × 6.34" 2-blade NAB folding propeller.
P1-LU01-E0	Pod 1.0 Evo Folding Propeller	9.96" × 6.34" 2-blade NAB folding propeller.
P1-LU02-E0	Pod 1.0 Evo Folding Propeller Anode	Applies to Pod 1.0 Evo Folding Propeller.
P3-LU02-E0	Pod 3.0 Evo Folding Propeller Anode	Applies to Pod 3.0 Evo Folding Propeller.
P6-M029-00	Pod 6.0 Evo Propeller LH	12.6" × 8.7" 3-blade aluminum propeller.
NE-LU22-00	NAVY 6.0 Evo AL Propeller LH	12.6" × 8.7" 3-blade aluminum propeller.
NE-LU01-U0	NAVY 6.0 Evo (2024) Propeller	11 3/10" x 8 1/2" 3-blade composite propeller.
X1-LU01-R0	X12 Propeller 11 13/16" x 10 5/8"RH	5-blade composite propeller.
X1-LU02-R0	X12 Propeller 11 7/16" x 14 /16"RH	5-blade composite propeller.



PART NO	PRODUCT	DESCRIPTION
X1-LU01-L0	X12 Propeller 11 13/16" x 10 5/8" LH	5-blade composite propeller.
X4-LU01-R0	X20/X40 Propeller 15" x 10 3/4" RH	5-blade aluminum propeller.
X4-LU01-L0	X20/X40 Propeller 15" x 10 3/4" LH	5-blade aluminum propeller.
X4-LU02-R0	X20/X40 Propeller 13 3/8" x 16 3/4" RH	5-blade aluminum propeller.
X4-LU02-L0	X20/X40 Propeller 13 3/8" x 16 3/4" LH	5-blade aluminum propeller.
PA-LU03-00	P12 Propeller 11" 4/5 x 9" RH	5-blade stainless steel propeller.
PA-LU02-00	P12 Folding Propeller	2-blade NAB folding propeller.

PART NO	PRODUCT	DESCRIPTION
EXTRAS		
VA-BG00-00	VAQUITA Carry Bag	Transport and store a complete Vaquita kit. Dust-resistant and washable.
S1-BG00-01	Spirit 1.0 Bag Set Plus	Made for easy transportation and storage of a Spirit outboard and a Spirit battery.
S1-BG01-01	SPIRIT 1.0 Outboard Bag Plus	Transport and store a Spirit motor. Dimension: 48.8 x 7.8 x 16.5 in / 124 x 20 x 42 cm.
S1-BG02-00	SPIRIT 1.0 Battery Bag	Transport and store a Spirit battery. Dimension: 11.8 x 7.8 x 16.5 in / 30 x 20 x 42 cm.
SP-M005-00	Spirit Motor Cowling	If a Spirit motor works with an E-Series battery, the original Spirit battery is removed. This cowling is put on the top for decoration purpose.
S1-TH02-00	SPIRIT Kill Switch	Shut down the motor upon the removal of this magnetic kill switch. A safety lanyard is included.
NE-SW00-00	Safety Wristband	IP67 wireless wristband works with Evo Tiller / Evo Remote Control. Shut down the motor in accidents. Max connection up to 8 units.
EB-DP00-00	E Battery External Display Panel	Diaplay panel for E40, E80, E175, E60, E163 Batteries.
S1-BA01-00	Spirit Battery Power Output Set	It is working with the Spirit battery activator to power other appliances.
SM-TH03-00	Side Mount Kill Switch	Shut down the motor upon the removal of this magnetic kill switch. A safety lanyard is included. Applies to Side Mount Control.
NE-DR02-00	Dual Remote Kill Switch	Shut down the motor upon the removal of this magnetic kill switch. A safety lanyard is included. Applies to Dual Remote Control.

PART NO	PRODUCT	DESCRIPTION
A1-CP00-00	GPS&Antenna Package	One GPS antenna and one 4G antenna.
A1-M001-00	Bus Box 250 A	Connect 96 V batteries with a DCDC converter, a charger and the ePropulsion motor.
A1-DC00-01	DC-DC 96 to 12 V 1 kW	Convert G-Series battery from 96 to 12 V.
EB-AC03-01	Bus Bar 150 A	Connect 48 V batteries with a DCDC converter, a charger or a MPPT solar charger.
EB-AC04-01	DC-DC 48 to 12 V 60 W	Convert E-Series battery from 48 to 12 V.

Follow ePropulsion on

